

Premier POWER PACK

EN54-4 POWER SUPPLY UNIT



INSTRUCTION MANUAL



CONTENTS

Introduction to the Premier Power Pack PSU.....	2
Changes to EN54-4 (The Fire Alarm Equipment Power Supply Standard)	3
Indications.....	4
LCD	4
LED External	5
LED Internal.....	5
Mounting the Power Supply	6
Electrical Connections.....	7
Electrical Safety Measures	7
Batteries.....	7
Connecting the Mains & Battery.....	8
Connecting Ancillary Equipment to the PSU.....	10
Recommendations for Cable to Auxiliary Equipment	11
Checking the Battery Charger Voltage.....	11
Choosing the Correct Battery Size	12
Technical Information	13
Maintenance Information.....	15
Manufacturer's Declaration.....	15

INTRODUCTION TO THE PREMIER POWER PACK PSU

The Premier Power Pack is an EN54 compliant Power Supply, intended to power ancillary fire alarm equipment.

It incorporates a small LCD screen that will give information about the Power Supply status (such as output voltage, output current, charger voltage etc).

It also displays basic information via its LEDs (Power/General fault / earth fault & Battery fault). These LEDs are located on the panel door, and also on the controller PCB itself.

The power supply has a 3 state charger. It will initially supply a BOOST charge current, until it has detected that the battery is close to full charge, then it will switch to FLOAT charging. If it detects flat or missing batteries, it will switch to PULSE mode, until it detects good batteries.

The PSU monitors batteries for High Internal resistance, and will report a fault if it detects a resistance that would prevent the PSU giving its rated output.

The power supply will prevent battery deep discharge by disconnecting the batteries when they reach their final voltage under a mains fail condition.

The Power pack PSU is also available as a "CIE version", used to power fire alarm panels. This version of the PSU is normally supplied without the current measuring feature.

The "Control panel" version does not have the LCD fitted, so will communicate its status via its internal LEDs only.

CHANGES TO EN54-4 (THE FIRE ALARM EQUIPMENT POWER SUPPLY STANDARD)

In 2006 the Fire alarm Power Supply Equipment standard changed, adding the requirement that a PSU should monitor the internal resistance of its batteries, and give a warning when it is above a certain level.

The reason for this is that when a battery's internal resistance increases, it will reach a point where the battery will no longer be able to supply the rated output voltage of the PSU under full load conditions. So under a mains fail condition, the Power supply, running on batteries only, could not supply its rated load.

For Example, if a 5 Amp power supply has batteries with 2 ohms internal resistance, when running on batteries, and supplying full load, there would be a 10V ($V=I \times R = 5 \times 2 = 10$ Volts) drop across the battery, meaning that the output voltage would be outside the working range of the power supply.

The Premier Power Pack range of power supplies will give a Battery Hi Internal resistance fault when the internal resistance for that power supply's rating is close to the level that would cause the working voltage to be out of range.

NOTE: Batteries reporting a high internal resistance WILL NOT BE CURED BY CHARGING ALONE. Either replace the batteries, or discharge & charge 3 or 4 times (Note that this will take several days, and is not guaranteed to cure the problem)

INDICATIONS

LCD

The Stand alone Premier Power Pack PSU has a 4 line LCD display, which can show the current state of the power supply.

The Power supply has 2 buttons. The first turns on the backlight. The second will scroll through the available display screens, showing the PSU's current state.

Screen 1: PSU Model information and System Normal / Power Supply Fault Indication

Z	E	T	A		A	L	A	R	M		S	Y	S	T	E	M	S		
P	R	E	M	I	E	R		P	O	W	E	R	-	P	A	C	K		
R	A	T	I	N	G		3	0	V		D	C	5	.	6	A			
S	Y	S	T	E	M		N	O	R	M	A	L							

This is the model information screen. It will give a general indication of the system state in the bottom line. System Normal for a healthy system. Power Supply Fault if there are any problems.

Screen 2: Mains / Battery Healthy, PSU output Voltage, PSU output current

M	A	I	N	S	:		O	K		B	A	T	T	S	:		O	K	
V	(A)	=	2	9	.	5		V	(B)	=	2	9	.	5	V
C	U	R	R	E	N	T		0	.	1	2		A	M	P	S			

This screen shows whether mains and battery are OK or BAD. It also shows the output voltage, and the current being supplied. In the event of a blown 24V output fuse, the screen will show V(A)=BAD or V(B)=BAD.

Screen 3: Battery Charger Info

B	A	T	T	E	R	Y		I	M	P	:	0	.	0	0	3	7		
C	H	A	R	G	E	R		V	O	L	T	:	2	5	.	4	5		V
C	H	A	R	G	E		T	Y	P	E	:		B	O	O	S	T		
B	A	T	T	E	R	Y		S	T	A	T	E	:	G	O	O	D		

This screen gives information about the battery & charger circuit. The Battery IMP(edance) is the internal resistance of the battery, explained in the recent changes to EN 54-4 section.

The Charger Voltage will be the voltage at the battery terminals.

The Charge Type gives the current charging method. The methods used are:-

- BOOST – Constant current charge of 920mA. Used when batteries are flat
- FLOAT – Float charge is applied as the batteries approach a full charge
- PULSE – used when the voltage at the charger terminals is less than the final voltage. Used to check if the batteries are present.
- OFF – Charger is turned off when no mains is present

The Battery state indicates whether the batteries are:-

- GOOD – Batteries are OK
- HI IMPEDANCE – High internal resistance detected
- FLAT – Battery voltage below final voltage. Batteries should be replaced
- REMOVED – Batteries have been disconnected

Screen 4: Misc Info

E	A	R	T	H	:	2	.	4	4	7	V					G	O	O	D
C	H	A	R	G	E	R		C	I	R	C	U	I	T	:		O	K	
B	A	D		B	A	T	T	E	R	Y		L	V	L		0	.	9	R

Shows the earth monitoring voltage (2.5V nominal), and whether a fault has been detected. The charger circuit is monitored to check if it is functioning correctly and charging batteries as expected. Bad battery level shows the battery internal resistance that would cause the power supply to report a fault.

Screen 5: Software Version Info

S	o	f	t	W	a	r	e		P	S	U	:		2	V	1	0		
S	o	f	t	W	a	r	e		L	C	D	:		1	V	0	0		

This screen shows the software versions of the PSU microcontroller and the display microcontroller.

LED EXTERNAL

The PSU external LEDs are:-

- Power (GREEN) Steady = mains present
Flashing = Mains fail
- General Fault OFF = No fault present
ON = Output fuse blown or removed, or mains low/fail (with flashing power good LED)
- Earth Fault OFF = No earth Fault present OR earth monitoring disabled
ON= Earth fault Detected. Check LCD screen for further info.
- Battery Fault OFF = Battery OK
ON = Battery Fault

LED INTERNAL

These are the same as the external LEDs. These are the only indications present when the PSU is used in a Control Panel. The General fault is labeled as charger fault.

MOUNTING THE POWER SUPPLY

The Premier Power Pack range of Power supplies are suitable for indoor use only.

Before fixing the Power supply to the wall, consider the planned cable entry. The Premier Power Pack PSU has top & bottom 20mm cable entries. If other entries are required, the box can be carefully drilled before fixing to the wall.

Fix the Premier Power Pack to a suitable sturdy Flat surface. Fitting the PSU at eye level will allow the panel's display to be easily read. Use Fixing screws suitable for the chosen surface, remembering that with batteries fitted, the Power supply will be quite heavy.

If additional cable entries have been cut into the box, ensure that all swarf has been removed. The cutout will probably have a sharp edge that could damage the cables. Use suitable insulation to cover the sharp edges.

Enclosure for Power Pack 2.0 / 12 (max Batteries 12Ah)

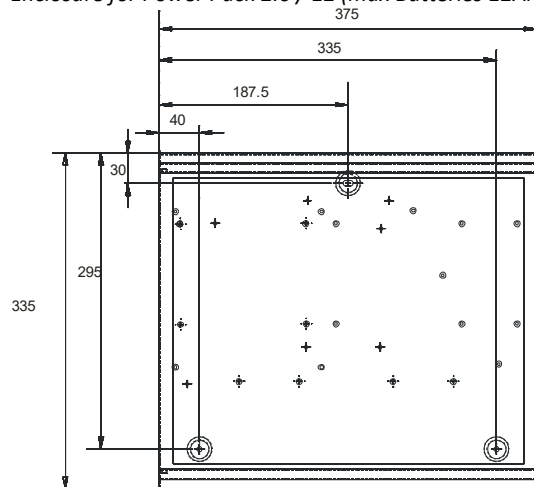

Enclosure for Power Pack 5.0 / 17 (max Batteries 17Ah)

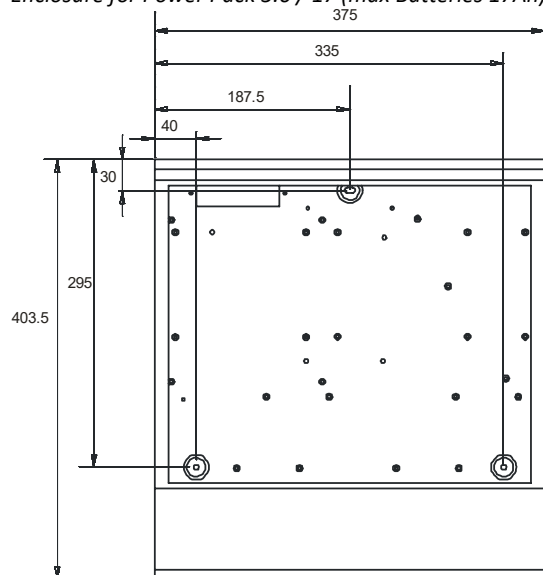

ELECTRICAL CONNECTIONS

ELECTRICAL SAFETY MEASURES

- ⚡ A licensed electrician must be present to connect to the mains if it is a fixed installation.
- ⚡ Connecting equipment to a consumer unit is potentially hazardous. Ideally, do not do this work alone. Alternatively, advise a colleague that you are about to undertake this work, and that you will call them back at a set time.
- ⚡ Check that the power supply, its cables, plugs and sockets are in good condition before installing. If there are signs of damage, contact your supplier to arrange a replacement.
- ⚡ Electricity can be dangerous. Conductive materials can cause a high short-circuit current which could cause serious burns.
- ⚡ Do not use any kind of metal equipment (Eg Screwdriver) inside the PSU without first unplugging the equipment.



NOTE: When the Power Pack is operating normally, i.e. not being tended by service personnel, the access door must be closed and locked. Also the electrical connectors on the power supply cage must be insulated using the provided plastic cover. After locking the access door, the key MUST be removed and ONLY held by the responsible person and / or the service personnel. It must under NO CIRCUMSTANCES be held by the user.

NOTE: Connecting this power supply to a fixed mains connection should only be carried out by a qualified electrician. The PSU is Class 1 Equipment and MUST be earthed.

BATTERIES

- ⚡ Batteries should be recycled. Leave the battery in a suitable recycling bin or return it to the supplier in the original packaging of the new batteries. Consult the new battery instructions to obtain more information on this.
- ⚡ Do not dispose of batteries by throwing them in fire, as they could explode.
- ⚡ Do not open or cut batteries; they contain an electrolyte that is toxic and harmful to the skin and eyes.
- ⚡ In order to prevent personal injury caused by hazardous currents, avoid wearing wristwatches and jewelry such as rings when replacing batteries. Use tools equipped with insulated handles.
- ⚡ When replacing batteries, use the same number and type of batteries installed in the equipment.
- ⚡ Consult your supplier to obtain information on battery equipment replacement and recycling batteries.

CONNECTING THE MAINS & BATTERY

The Power Supply should be connected to 230V AC by a 3A rated spur to the fuse box with 1.0mm² to 2.5mm² 3-core cable. Nothing else should be connected to this supply

The mains input is to be connected to the PSU Cage. The Live, Earth and Neutral connections are marked on the switch mode cage.

The incoming mains cable should be kept separate from the other cables to help minimise mains interference.

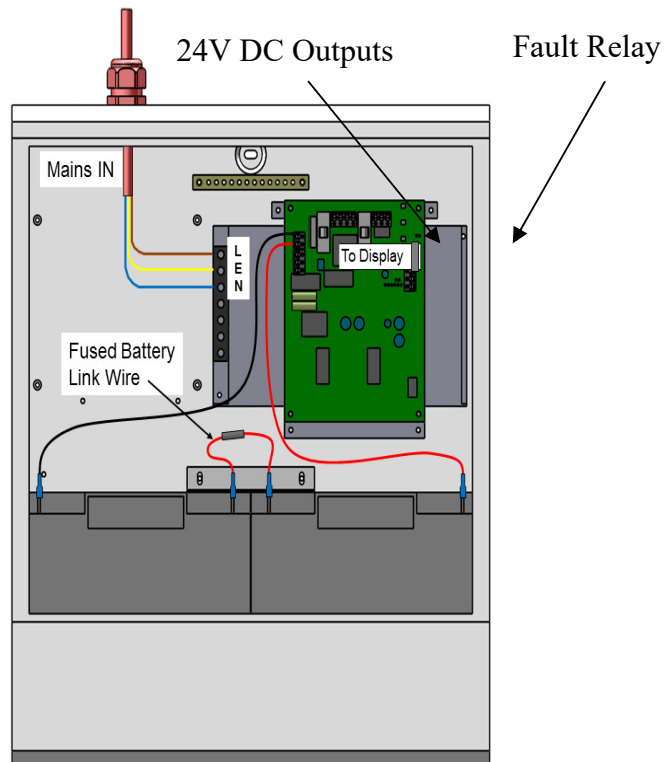

The two batteries are wired in **series**.

The **+ve** of one battery is connected to the **red** battery charger lead.

The **-ve** of the other battery is connected to the **black** battery charger lead.

The **-ve** of the first battery is connected to the **+ve** of the second battery using the FUSED link wire supplied.

The battery clamp brackets should then be fitted to prevent vibration damage to the Power Supply.

For 7 Ah / 12 Ah Batteries (Power Pack 2.0)

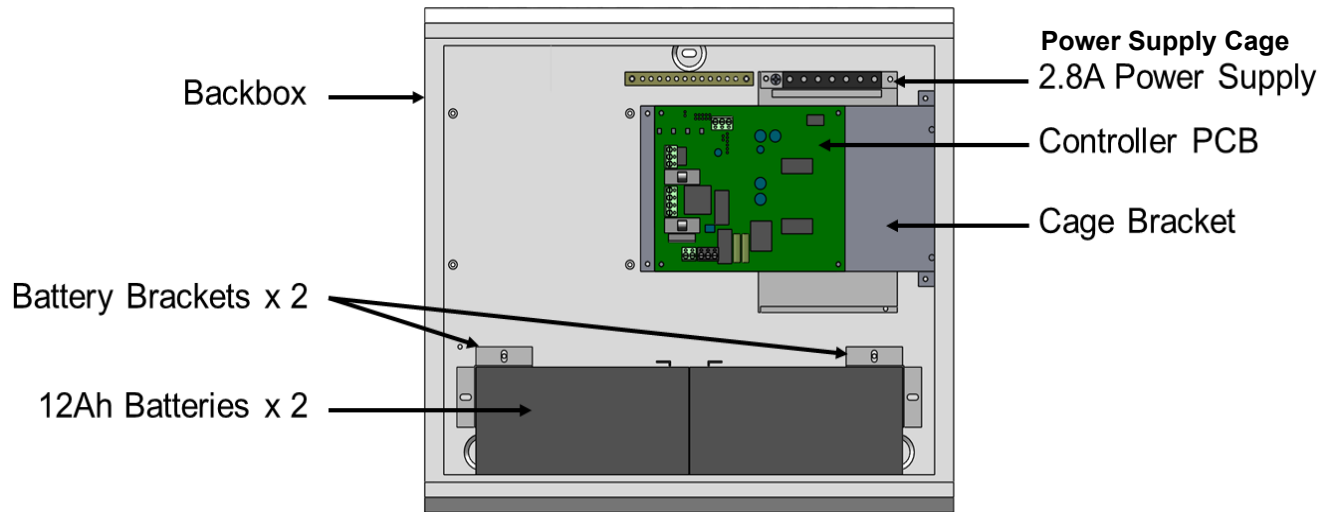

For 17 Ah Batteries (Power Pack 5.0)

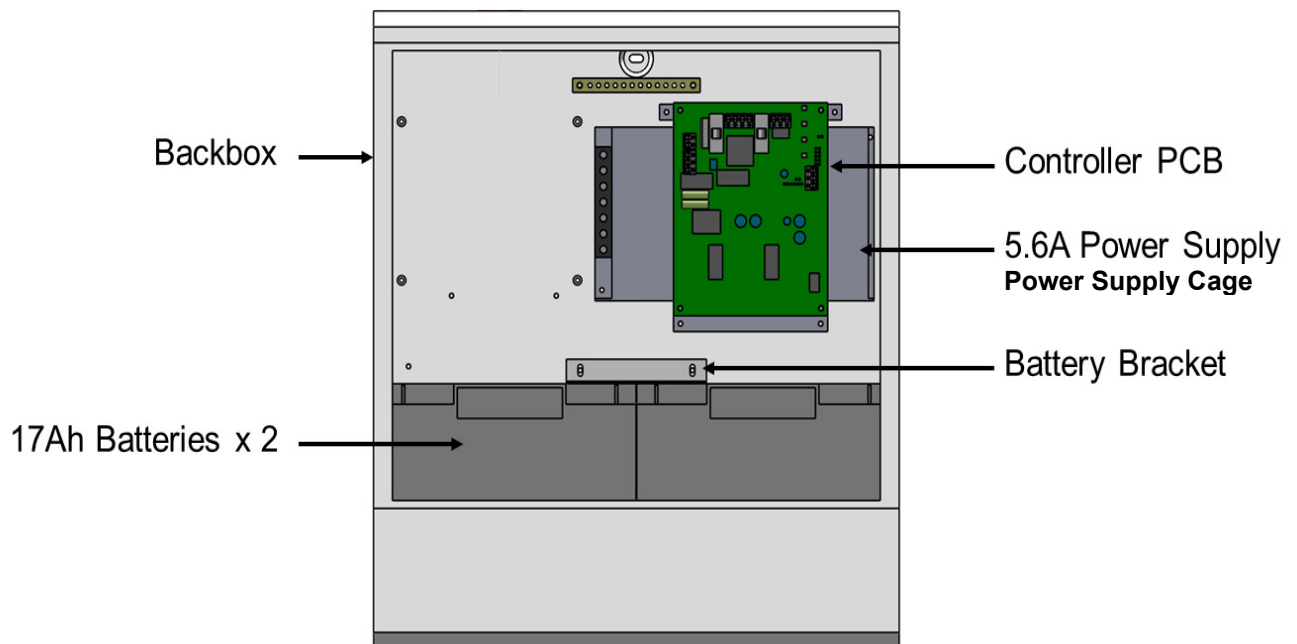

The Recommended Battery types are:

POWER SUPPLY VERSION	MINIMUM RECOMMENDED SIZE	MAXIMUM RECOMMENDED SIZE
Premier PowerPack 2/12	Powersonic 12V 2Ah	Powersonic 12V 12Ah
Premier PowerPack 5/17	Powersonic 12V 7Ah	Powersonic 12V 17Ah

CONNECTING ANCILLARY EQUIPMENT TO THE PSU

The Ancillary equipment to be powered by the power supply should be fitted to the power supply output connections. Note that the PSU has 2 outputs labeled 24V A and 24V B, each fused at half the total output.

Connect to a single output if the maximum current is less than half the maximum rated output of the power supply.

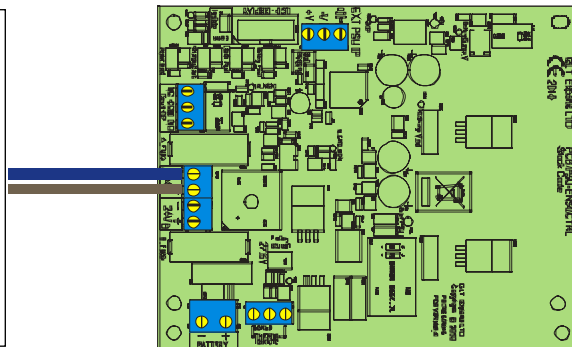

Two separate loads can be powered separately by using the both output channels.

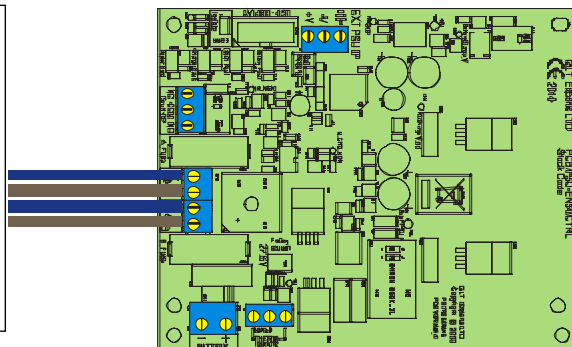

If the application requires current more than one output can supply, then both outputs should be used. The Positives should be commoned together as shown. . The Negatives are already commoned on the controller PCB so do not need to be commoned externally.

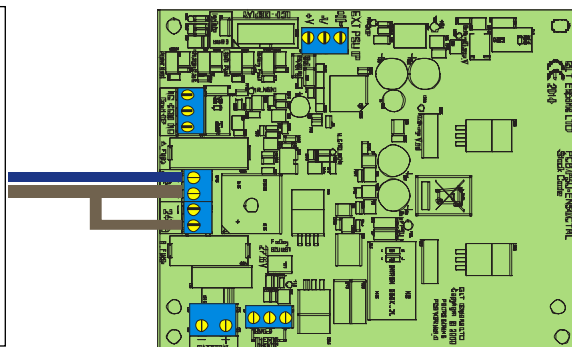

The Fault Relay is used to communicate the status of the PSU to ancillary equipment.

The relay is normally energized, so that it can signal a fault in the event of total power failure.

The NO terminal (red wire) is connected to the Common terminal (yellow wire) in the system normal condition.

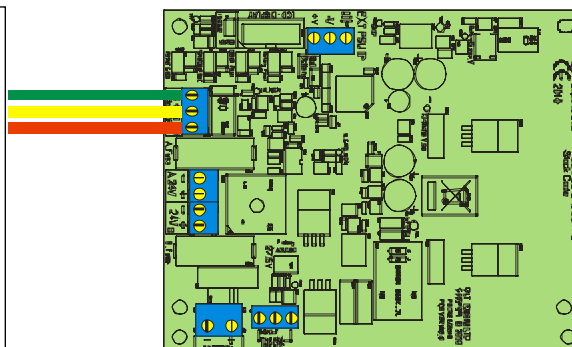

RECOMMENDATIONS FOR CABLE TO AUXILIARY EQUIPMENT

BS5839 Part 1 recommends that all parts of a fire system are wired in a shielded fire resistant cable.

It is recommended to use 2 core (plus screen) cable with conductor cross section between 1.5mm² and 2.5mm²

If the power supply is used for non BS5839 fire alarm purposes, many other types & sizes of cable may be suitable.

CHECKING THE BATTERY CHARGER VOLTAGE

The Premier Power Pack Power Supply, like many other EN 54 Power supplies, will turn off its battery charger when the batteries are disconnected. To check the charger voltage it will be necessary to set the unit into configuration mode.

To do this:-

1. Disconnect batteries & turn off mains
2. Fit a jumper link to the Sel. Battery jumper.
3. Turn on Mains.
4. If the PSU has a LCD screen it will display "FACTORY CALIBRATE – FLOAT-V Adjust POT"
5. The charger leads will now show the float charge voltage which is nominally 27.3V DC at 25 °C
6. The Charger Potentiometer is factory Preset, and should not be altered. If the charger voltage is more than half a volt different to the voltage shown on the table below, contact your supplier.

TEMPERATURE	CHARGER VOLTAGE
-5	28.02
0	27.90
5	27.78
10	27.66
15	27.54
20	27.42
25	27.30
30	27.18
35	27.06
40	26.94
45	26.82
50	26.70

CHOOSING THE CORRECT BATTERY SIZE

The Premier Power Pack power supplies can use a wide range of battery sizes.

To help determine the most suitable battery size, the following points need to be considered:-

1. What will be the normal operating output current of the PSU. Will it be a high load (e.g. door holders), or a small load (e.g. a sounder circuit controller)
2. What will be the alarm load?
3. What is the required standby time?
4. What is the required alarm time?

In general, applications with a higher quiescent current load will require bigger batteries, if they also require a high standby time.

Typical Battery requirements for a Power Pack 5.0A Power supply

APPLICATION	CURRENT LOAD	STANDBY	REQUIRED AMP HOUR	TYPICAL BATTS	CHARGE IN EN54 TIME
Auto Dialler	50 / 100 mA	72 Hours	4.5 Ah	7 Ah	Yes
GSM Com	200 / 500 mA	48 Hours	12.3 Ah	12 Ah	Yes
Door holders	2 A load	24 Hours	60 Ah	60 Ah	NO
Door holders	2 A load	2 Hours	5 Ah	7 Ah	Yes
Door holders	4 A load	2 Hours	10 Ah	12Ah	Yes
ZSCC (1 unit)	40mA / 1A	24 Hour	1.8 Ah	2.2 Ah	Yes
ZSCC (5 units)	200mA / 5A	24 Hours	9.2 Ah	12 Ah	Yes
FyreSense Aspiration Unit	500mA	24 Hours	15.3 Ah	17 Ah	Yes

TECHNICAL INFORMATION

OVERALL SPECIFICATION	5.0 A PSU	2.0 A PSU
MAINS INPUT		
Nominal Mains Supply Voltage	230V AC	230V AC
Cage Input voltage range	88~132 VAC / 176~264 VAC 47~63 Hz ;	88~264 VAC 47~63 Hz ;
AC input current	2.4 A/115 V 1.6A/ 230 V	2.0A/115 V 1.2A/ 230 V
Efficiency	86%	85%
AC inrush current	Cold starting current 45A/230VAC	Cold starting current 40A/230VAC
Leakage current	< 2 mA/240VAC	< 2mA/240VAC
SWITCH MODE CAGE OUTPUT		
Nominal DC Output voltage	30V	30V
Output Voltage Error	+/- 1%	+/- 1%
Output Power	150W	75W
Rated output current @ 30V DC	5 A	2.5 A
Adjustable range for DC voltage	27 – 30.6V	27 – 33V
Setup rise hold up time	800ms,20ms,24ms, Full-load	500ms,30ms,60ms Full-load
Switching Frequency	60kHz	60kHz
PSU OUTPUT		
Nominal DC Output voltage	30V	30V
Output Voltage Range	19 – 31 V DC	19 – 31 V DC
Maximum PSU output while charging I MAX A	4.1A	1.4A
I MAX B	N/A	N/A
I MIN	0 mA	0mA
Output Fuses	2 x T2.5A	2 x T1.0A
Output Voltage Ripple	Typical 120mVp-p (Max 500mV)	Typical 150mVp-p (Max 500mV)
Fault Output	Normally Energised Volt-Free Change over Relay: SELV @ 1A	Normally Energised Volt-Free Change over Relay: SELV @ 1A
BATTERY BACKUP		
Battery type	2 x 12V Sealed Lead Acid Batteries connected in SERIES	2 x 12V Sealed Lead Acid Batteries connected in SERIES
Battery Size Range	7.0 – 17 Ah	2.0 – 12 Ah
Charger Type	CPU controlled 3 state charger (boost, float, pulse modes)	CPU controlled 3 state charger (boost, float, pulse modes)
Boost Charging current	920mA	750mA
Float Charging current	200mA Typical	200mA Typical
Pulse charging	10% duty cycle	10% duty cycle
Battery fuse	F5A (in battery link lead)	F5A (in battery link lead)
Maximum battery internal resistance	0.9 ohm	2.0 ohm
Battery Deep Discharge Disconnect	20.5 Volts At battery (19V at PSU output)	20.5 Volts At battery (19V at PSU output)
Deep Discharge Reconnection	When mains restored	When mains restored
Charger Temp. Compensation	-36mV/°C typical (27-46 mV/°C)	-36mV/°C typical (27-46 mV/°C)
PSU Battery Drain – in Mains Fail	25mA (40 mA with LCD Screen)	25mA (40 mA with LCD Screen)
Max Battery Monitoring Current (R int test)	460mA	460mA
LED INDICATIONS (PSE and CIE Version)		
GREEN Power	Steady = Mains OK Flashing = Mains Fail	Steady = Mains OK Flashing = Mains Fail
General Fault	Flashes on Mains Fail or Output voltage failure	Flashes on Mains Fail or Output voltage failure
Earth Fault	Flashes on +VE or –VE earth fault (if enabled)	Flashes on +VE or –VE earth fault (if enabled)
Battery Fault	Flashes on any battery fault.	Flashes on any battery fault.

LCD DISPLAY (PSE Version Only)		
Default Screen	Manufacturer brand name Model System Normal	Manufacturer brand name Model System Normal
Information screen 1	A = mains OK, Batts OK B = Not used C = V(A) & V(B) output voltages D = Load current	A = mains OK, Batts OK B = Not used C = V(A) & V(B) output voltages D = Load current
Information screen 2	A = Battery Impedance B = Charger voltage C = Charge Type D = Battery condition	A = Battery Impedance B = Charger voltage C = Charge Type D = Battery condition
Information screen 3	A = Earth voltage & condition B = Charger State C = Bad Battery Level D = Not used	A = Earth voltage & condition B = Charger State C = Bad Battery Level D = Not used
Information screen 4	A = Not used B = Not used C = PSU Software version D = LCD Software version	A = Not used B = Not used C = PSU Software version D = LCD Software version
PROTECTION PROPERTIES		
Overload protection	110%~150%	110%~150%
Overload protection Type	Hiccup mode, automatic recovery	Hiccup mode, automatic recovery
Over-voltage protection	33.35 ~ 39.15V	33.5 – 39V
Over-voltage protection Type	Hiccup mode, auto recovery	Hiccup mode, auto recovery
ENVIRONMENT		
Working temperature and humidity	-25°C~+70°C ; 20%~90 %RH	-25°C~+70°C ; 20%~90 %RH
Store temperature and humidity	-40°C~+85°C ; 10%~95 %RH	-40°C~+85°C ; 10%~95 %RH
Vibration	10~500Hz, 5G 10min./1cycle, Duration 60 minutes, three axis	10~500Hz, 5G 10min./1cycle, Duration 60 minutes, three axis
SAFETY		
Isolation voltage	I/P-O/P:3KVAC I/P-FG:1.5KVAC O/P-FG:0.5KVAC	I/P-O/P:3KVAC I/P-FG:1.5KVAC O/P-FG:0.5KVAC
Isolation resistance	I/P-O/P,I/P-FG,O/P-FG: 100M Ohms/500VDC	I/P-O/P,I/P-FG,O/P-FG: 100M Ohms/500VDC
STANDARDS		
Design Standard	EN 54 Part 4:1997/ A2:2006	EN 54 Part 4:1997/ A2:2006
Safety standards	UL60950-1	UL60950-1
EMC standards	Meets EN55022, EN61000-3-2, -3, EN61000-4-2,3,4,5,6,8,11; ENV50204, EN55024, EN60950-1	Meets EN55022, EN61000-3-2, -3, EN61000-4-2,3,4,5,6,8,11; ENV50204, EN55024
PHYSICAL		
Dimensions	375 x 403 x 128 mm	375 x 335 x 128 mm
Weight (Excluding Batteries)	3.55Kg	3.0 Kg

MAINTENANCE INFORMATION

The following maintenance should be carried out at least once per annum:

- a) Check that the output voltage of both outputs is within the range specified in the Technical Information section;
- b) Check the charger voltage using the instructions in this manual;
- c) Check the battery condition. Look for signs of leakage or corrosion. Make sure that the battery leads are securely attached to the battery terminals;
- d) Check for damage to the insulation of all electrical cables;
- e) Check that a fault is reported when the AC mains are switched off;
- f) Check that a fault is reported when one of the battery leads is disconnected.

MANUFACTURER'S DECLARATION

I hereby declare that the design of the 5A Premier Powerpack PSE has been carried out in accordance with a quality management system which incorporates a set of rules for the design of all elements of the PSE;

and the components of the 5A Premier Powerpack PSE have been selected for the intended purpose and are expected to operate within their specification when the environmental conditions outside the cabinet of the PSE conform to class 3K5 of EN 60721-3-3:1995.

Geoff Walker
Approvals Manager
GLT Exports Limited

1st July 2011

 0905
Zeta Alarms Limited 72-78 Morfa Road, Swansea SA1 2EN 12 0905-CPR-00146
EN54-4:1997+A1:2002 + A2: 2006 Power supply equipment for fire detection and fire alarm systems for buildings Premier PowerPack PP2/12, PP5/17 Other Technical Data: See Doc: "Simplicity Plus Product file" held by the manufacturer

Manual Modification History

Do not print this Page when creating PDF Of the manual

GLT.MAN-138

ISSUE	DATE	CHANGES
1.00	10/5/2010	Initial Release
1.01	29/7/2010	Drawings changed to show mains filter
1.02	23/9/2010	Font Size Adjusted to make pages more uniform
1.03	15/4/2011	"Keep enclosure locked" warning added
1.04	15/4/2011	<ul style="list-style-type: none"> ⤴ Page 9, Para 2 – L,E,N connectors marked on cage (not filter) ⤴ Page 9, Drawing – Remove filter & mains in cable to cage ⤴ Page 10, Drawing 2A Powerpack – Remove filter & rotate cage through 180 degs ⤴ Page 10, Drawing 5A Powerpack – Remove filter ⤴ Pages 14 to 16 – technical info unchanged, awaiting data sheet for 30V cage (previous data sheet was 24V output).
1.05	26/4/2011	Picture of lock & label added to keep locked warning Removed mains filter (Meanwell cage does not need it) Cage Specs adjusted.
1.06	5/6/2011	Revert to LDG cage (as 150W LDG cage passed tests) Mains filter added back into drawings Added note to put mains cover on terminals Cage specs adjusted back to LDG cage Added Manufacturer`s declaration.
1.07	1/7/2011	Added maintenance Information
1.08	19/10/2011	Meanwell cage version Removed notice about fitting cover to mains filter (no mains filter used) Diagrams amended Added note that CIE version may not have current measuring feature Added note that CIE version does not have an LCD Changed shade of blue used in the tech spec tables Changed cage specs back to 30V Meanwell cage Total I for PP2-12 changed to 2.5A Imax A changed to 1.75 A
1.09	20/4/2012	Added revision history page Corrected Typo – Batteries section – missing word "supplier" I MAX A changed back to 1.4A Streamlined PSU specification pages
1.10	14/6/2012	Corrected nominal mains voltage to 230V AC
1.11	15/6/2012	Added Recommended Cable Added Recommended Batteries
1.12	12/07/2012	Updated Images Fixed formatting issues
1.13	27/7/2012	Redo Header & footer removed in error Added CE box Corrected Lock Label to Grey
1.14	25/11/2013	Amended Charge voltage table. Rescaled "squashed" How to fit battery pictures
1.15	19/5/2016	Added Switching frequency 60 kHz Added F / T prefix to fuse ratings
1.16	25/5/2017	Updated Company name to Zeta Alarms Limited
1.17	6/5/2021	Updated NB info on CE box